



## UNINTERRUPTIBLE POWER SUPPLY



The NS KING ST E PF1 series represents the latest generation of UPS PF1 in three-single-phase medium power transformer-less systems (VFI-SS-111).

NS KING ST E provides the perfect solution for small to medium sized data centers, communication rooms, IT networks, and any mission critical application that requires high power and energy efficiency.

NS KING ST E has a solution with integrated internal batteries from 10 to 20kW, reducing the footprint to a minimum. Available in three cabinet solutions, they are distinguished by the ability to contain a different number of batteries or accessories, such as an output isolation transformer, air filters on the front door or higher levels of IP protection.

## PRINCIPLES OF WORKING

Under normal power supply conditions, the load is powered directly by the Inverter while the rectifier supplies the necessary power to the Inverter and to charge the batteries.

If one of the following conditions occurs on the power supply network: power failure, lack of a phase, voltage out of tolerance, the battery provides the necessary energy for the inverter to power the load without interruption. Once normal operating conditions have been restored, the rectifier charges the battery and at the same time powers the load through the inverter.

If one of the following conditions occurs: overload, Inverter output voltage out of tolerance, Inverter input voltage out of tolerance, Inverter fault, overtemperature, the load is automatically transferred, without interruption, to the emergency network. When normal operating conditions are restored, the load is automatically transferred back to the Inverter.

## FEATURES

- Input power factor 0.99
- Output power factor PF1, kVA = kW
- Harmonic distortion THiD input  $\leq 3\%$
- 96.6% VFI efficiency
- 5" graphic touchscreen display
- three different frame types available
- Transfer time zero
- Sinusoidal voltage, filtered stabilized
- Intelligent battery management
- Cold start
- Parallelable up to 8 units (N + 1)
- Full discharge battery protection.
- ONLINE / OFFLINE operating mode
- RS232, basic contact port and Bluetooth

### Optional

- SNMP interface, RS485, dry contacts
- Isolation transformer
- Synchronization kit
- Parallel kit
- Back feed protection
- Battery temperature probe
- Local temperature probe
- LCD remote panel
- External manual bypass
- Separate emergency line (standard in C cabinet version)

## CONTROL PANEL

ELIT's UPS are equipped with a colored graphic touch screen display providing UPS information, measurements, operating states and alarms in different languages.

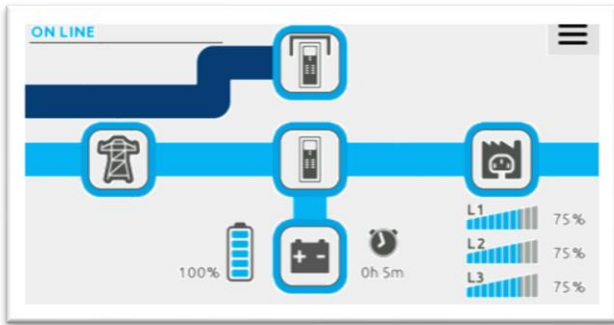

## INTERFACES

The NS KING ST E series UPS is equipped with a standard USB interface, EPO terminals for NC emergency shutdown, 2 slots for SNMP and additional accessory cards such as RS485 Modbus, contact port, slot for parallel and connection accessory card for external battery temperature probe. It is also possible to add an external manual by-pass to the UPS for maintenance, which allows, for example, to replace the UPS without interrupting the load.

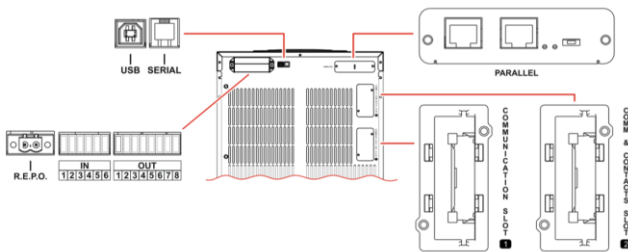

## N+X POWER SCALABLE PARALLEL

This function, with the dedicated accessory card inserted in the appropriate slot, allows the UPS to operate in redundancy, when the necessary power is lower than the rated power of the single group (N + 1), and to operate in power (2N) when for inrush or more power needed, the power of the single UPS is exceeded.



## INPUT AND OUTPUT

With its flexible range of three cabinet solutions A-B-C, ELIT NS KING ST E pf1 is suitable for use in a wide range of applications. In/outlet terminals are placed in the front bottom under the switch isolators of the apparatus in B-C cabinet version and rear in A version. On request is possible to provide the apparatus with input/output and battery terminals from the top.

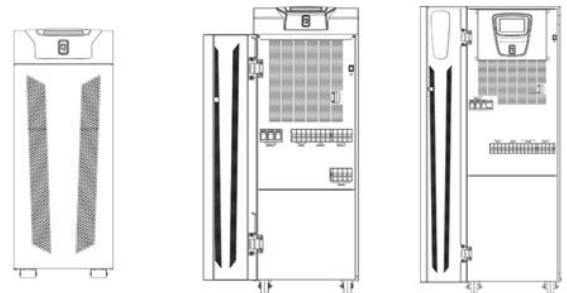

CAB A	CAB B	CAB C
	3ph or 1 ph	
Rear, dedicated terminal cover	Bottom front	Bottom front
No, front cover	Yes	Yes
	Yes	
SWIN, SWOUT, SWMB	SWIN, SWOUT, SWMB (SWBYP optional)	SWIN, SWOUT, SWMB, SWBYP
Not Applicable	Optional (Ex-works/on site)	Standard
UPS Internal battery protection		
1x 40 blocks	1-2x 40 blocks	1-3x 40 blocks
	Standard	
Horizontal	Horizontal	Horizontal
	Standard	
Not Applicable	Not Applicable	Standard

## BLOCK DIAGRAM

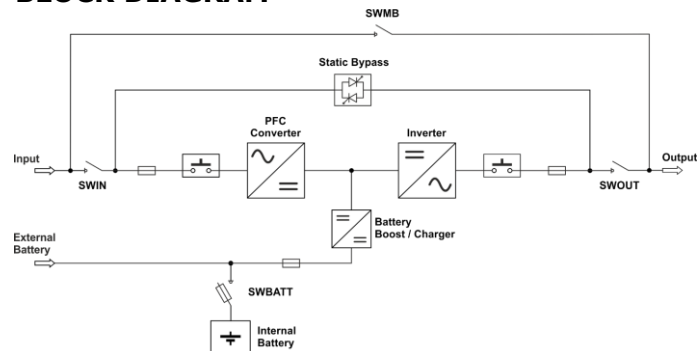



MODEL	NS KING ST E 10	NS KING ST E 15	NS KING ST E 20
Rated power kVA/kW	10/10	15/15	20/20

INPUT			
Voltage	220-230-240Vac 1PH+N+PE		
Voltage tolerance without switching to battery power	184 - 276V @100% load 140 - 276V @50% load		
Power factor	0.99		
Frequency	40 ÷ 72Hz		
Total Harmonic distortion (THDi)	≤2.5% with full load and source THDv <1%		
Peak current	Absent		

OUTPUT			
Nominal voltage	220-230-240Vac 1PH+N+PE		
Voltage stability	±0.5% static stability; ±1% dynamic stability		
Voltage distortion	< 1% with linear load; ≤ 1.5% with distorting load (EN62040-3)		
Nominal frequency	50Hz or 60Hz		
Frequency stability	±0.01%		
Waveform	Sinusoidal		
Transfer time	0 ms.		
Output power factor	1		
Efficiency	95.83%	96.06%	95.75%
Overload	110% 60 min - 125% 10min - 150% 60sec - 200% 0.5sec - > 200% 0.2sec		
Short circuit current PH-N	2.7 x In for 200 msec + 1.5In for 300 msec (standalone)		

BATTERY			
Tipo	Lead-Acid / NiCad / Lithium		
Battery charger batterie	4A @full load 6A @94% load	6A	6A
Battery voltage	±240Vdc		

MISCELLANEOUS			
Relative ambient humidity	5 - 95% (without condensing)		
Ambient temperature	0°C +40°C		
Audible noise at 1 mt	51 @ 50% load 55 @ 100% load	55 @ 50% load 60 @ 100% load	55 @ 50% load 60 @ 100% load
User interfaces	USB, EPO - 2x Slot for accessory cards (SNMP, RS485, RS232, dry contacts), 1x Slot for accessory parallel card		
Color	RAL9017 dark grey		
Dimensions mm	Cabinet A: 280x840x700mm Cabinet B: 380x850x1025mm Cabinet C: 440x840x1320mm		
Weight without battery	Cab A: 48kgs Cab B: 72kgs Cab C: 103kgs	Cab A: 50kgs Cab B: 74kgs Cab C: 105kgs	Cab A: 52kgs Cab B: 76kgs Cab C: 107kgs
Cabinet protection degree	IP20		

STANDARDS	
Safety	EN 62040-1
EMC	EN 62040-2
Performance	EN 62040-3